

80 WATT

POWERFUL PERFORMANCE. SHARP RELIABILITY.

POLY-CRYSTALLINE SILICON PHOTOVOLTAIC MODULE WITH 80W MAXIMUM POWER

Sharp's NE-80EJEA photovoltaic modules offer industry-leading performance, durability, and reliability for a variety of electrical power requirements. Using breakthrough technology perfected by Sharp's 45 years of research and development, these modules incorporate an advanced surface texturing process to increase light absorption and improve efficiency. Common applications include cabins, solar power stations, pumps, beacons, and lighting equipment. Designed to withstand rigorous weather conditions, a junction box is also provided for easy electrical connections in the field, making Sharp's NE-80EJEA modules the perfect combination of advanced technology and reliability.



Solder-coated grid results in high fill factor performance under low light conditions.



Sharp multi-purpose modules offer industry-leading performance for a variety of applications.



FEATURES

- High-power module (80W) using 125mm square poly-crystalline silicon solar cells with 12.40% module conversion efficiency
- Sharp's advanced surface texturing process increases light absorption and efficiency while providing a more subdued, "natural" look
- Bypass diodes minimize the power drop caused by shade
- Water white, tempered glass, EVA laminate, plus aluminum frame for extended outdoor use
- Junction box for easy electrical connections in the field
- Nominal 12VDC output for battery charging applications
- Certifications: UL 1703, cUL, FM
- Sharp modules are manufactured in ISO 9001 certified facilities
- 25-year limited warranty on power output (see dealer for details)

ELECTRICAL CHARACTERISTICS

Cell	Poly-crystalline silicon
No. of Cells and Connections	36 in series
Open Circuit Voltage (Voc)	21.6V
Maximum Power Voltage (Vpm)	17.3V
Short Circuit Current (Isc)	5.16A
Maximum Power Current (Ipm)	4.63A
Maximum Power (Pmax)*	80W (+10% / -5%)
Module Efficiency (ηm)	12.40%
Maximum System Voltage	600VDC
Series Fuse Rating	10A
Type of Output Terminal	Junction Box

* (STC) Standard Test Conditions: 25°C, 1 kW/m², AM 1.5

MECHANICAL CHARACTERISTICS

Dimensions (A x B x C below)	47.28" x 21.14" x 1.81" 1200mm x 537mm x 46mm
Weight	20.94lbs / 9.5kg
Packing Configuration	1 pc per carton
Size of Carton	53.15" x 27.56" x 2.95" 1350mm x 700mm x 75mm
Loading Capacity (20 ft container)	242 pcs (242 cartons)
Loading Capacity (48 ft container)	506 pcs (506 cartons)

ABSOLUTE MAXIMUM RATINGS

Operating Temperature	-40 to +194°F / -40 to +90°C
Storage Temperature	-40 to +194°F / -40 to +90°C

IV CURVES

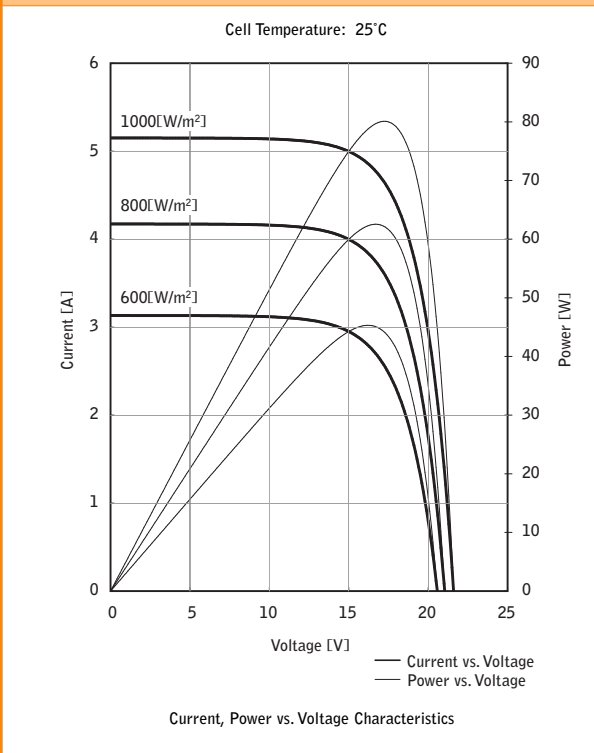

DIMENSIONS

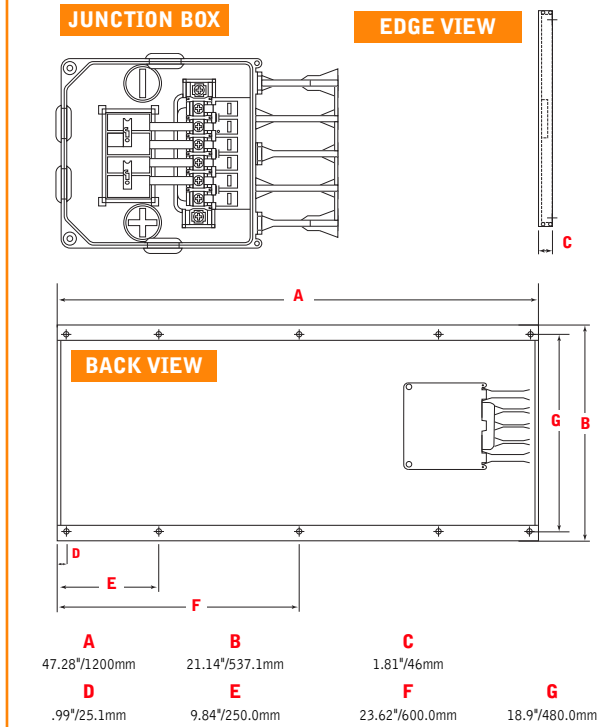

Design and specifications are subject to change without notice.

Sharp is a registered trademark of Sharp Corporation. All other trademarks are property of their respective owners.

Sharp takes no responsibility for any defects that may occur in equipment using any Sharp devices.

Contact Sharp to obtain the latest product manuals before using any Sharp device.

07F143

